

# EXCEL™ UltraBolt™

## Jack bolt tensioning system

Our patented design locking bolts ensure precise, uniform preload and eliminate the need for a torch ring. Our engineering group has created a solution that makes your liner changes faster, easier and safer. The unique design protects the threads of the locking bolt and head.

### Innovative design

- Rebuildable with EXCEL™ replacement components
- AR400 sleeve protects the UltraBolt from wear
- Silicone seal protects head threads from dust
- Precision preload

### Benefits

- Cost effective
- Extended life
- Quick and safe mantle maintenance
- Easier assembly and disassembly
- Eliminates the need for a torch ring
- Eliminates dangerous slug wrench

# Safety you deserve at every liner replacement

## Problems with traditional design

The traditional jack bolt tensioning design is hazardous every time maintenance is required. During removal and installation, it requires people to swing a weighted object against a slug wrench, which can lead to injuries. It also involves a consumable torch ring that must be cut to remove it, typically while the ring is under compression.

## Upgrade Solution

Our UltraBolt™ design makes your safety a priority. We have eliminated the need for a slug wrench by instead using a uniform preload system of bolts to tighten the jacking bolt.

Torch rings are a thing of the past with the UltraBolt. Our design uses a unique thrust plate that is not consumed during installation. The thrust plate protects the bolt from impact to ensure a long lasting product designed to save you money in the long run with minimal spares needed for a liner change.

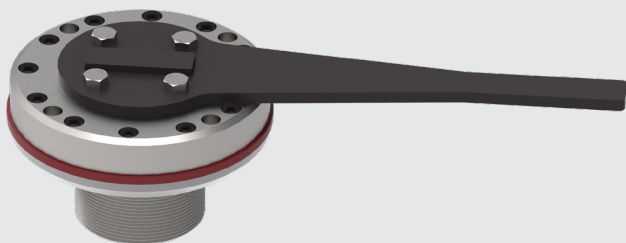

UltraBolt wrench used to lower locking bolt before tightening the jack bolts

## Quality redefined

We know that your success depends on reliable, high quality tools and components. We design our UltraBolt - jack bolt tensioning system for OEM gyratory and cone crushers with the same dedication and commitment to quality as we do for our own crusher tools.

Trust our expertise and strict standards in metallurgy and machining process. Our rigorous quality assurance protocols ensure that you get the dependability you deserve. We are ISO 9001 certified.

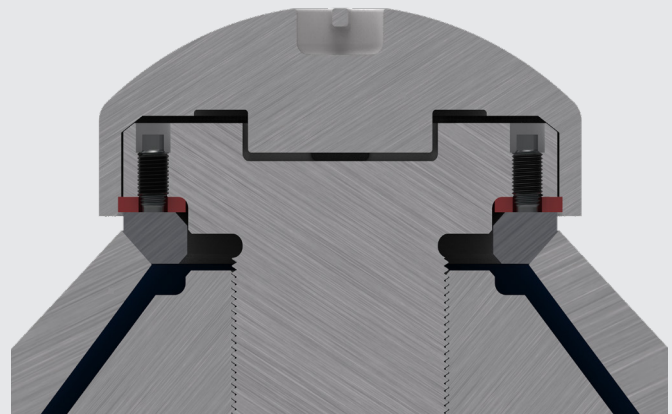

Section view of complete UltraBolt™ assembly with feed plate

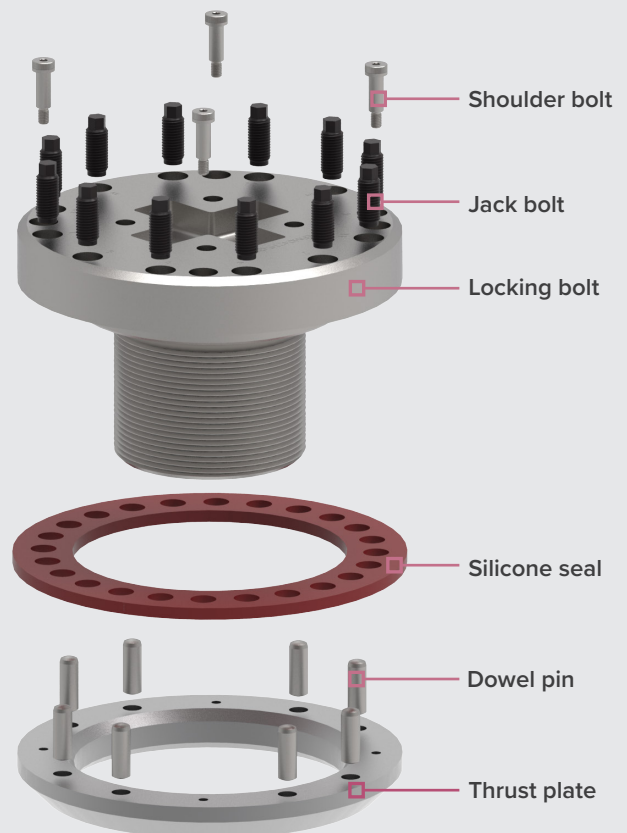

**FLSmidth A/S**  
Vigerslev Allé 77  
2500 Valby  
Denmark  
Tel: +45 3618 1000  
Fax: +45 3630 1820

**FLSmidth Inc. Pekin Operations**  
1 Excel Way  
Pekin, IL 61554  
Tel +1 309 419 8339  
Fax +1 309 347 6182  
Email: excelparts@flsmidth.com

[www.flsmidth.com](http://www.flsmidth.com)

Copyright © 2021 FLSmidth A/S. ALL RIGHTS RESERVED. FLSmidth and MAAG are (registered) trademarks of FLSmidth A/S. This brochure makes no offers, representations or warranties (express or implied), and information and data contained in this brochure are for general reference only and may change at any time.